

CHIP DUMPS

Chip Storage Table

Features

1. **Chip shute** - Manufactured from 1.6mm grade 430 st/steel.
2. **Top** - Manufactured from 0.9mm grade 430 st/steel.
3. **Lamp** - Food safe heating lamp.

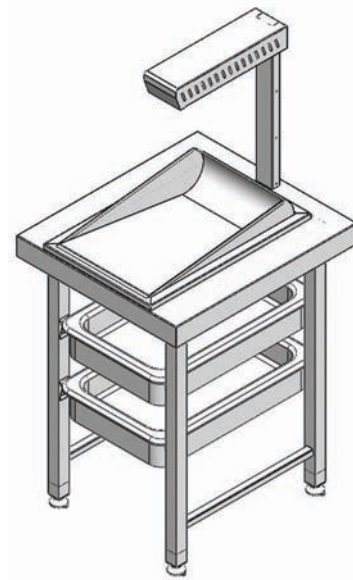

Drawings

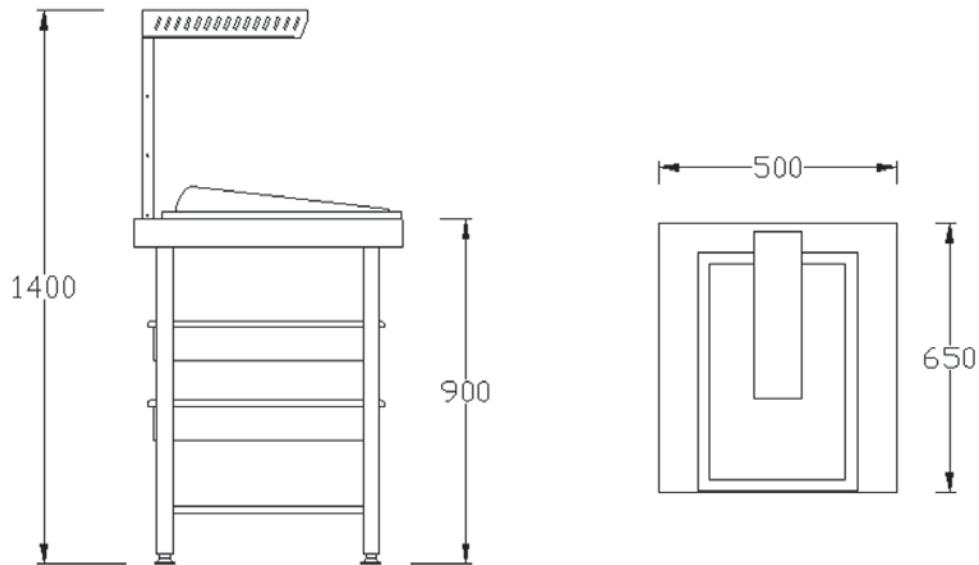

Specifications

Dimensions: 500(W) x 650(D) x 1400(H)
 Power consumption: 15 amp 220 volt
 Electrical connection: 2 meters (3 core) cable with fly leads

Optional Extras

Table top can be manufactured from: 1.2mm 430 st/steel
 0.9mm 304 st/steel
 1.2mm 304 st/steel
 Inserts 2 x full gn 1/1 inserts