

CANOPIES

BF-600-B (Box)

Features

Construction facilitates the insertion of filters that extend from the left to the right across the canopy length to ensure an even flow of air over the entire length. Seams are continuous throughout the length and width (there are no upstanding or protruding joints). All the joints are welded together, ground and polished to the original material texture. The use of bolts, nuts and rivets are avoided. All sharp edges and burs are cleaned and polished to ensure safety of cleaning personnel. Internal crevices between canopy joints are filled with a polyurethane or silicone sealer.



Filters

Impingement baffle type filters are manufactured from 0.7mm grade 430 st/steel. Filters are easily fitted without the use of tools. They slide into the position provided by the filter housing frame. When fitted in position the filter also acts as a fire barrier. The filters are self draining and do not block with grease when used for prolonged periods without cleaning intervals.

Application

Extracts steam and grease vapour produced by present day catering equipment.

Drawings

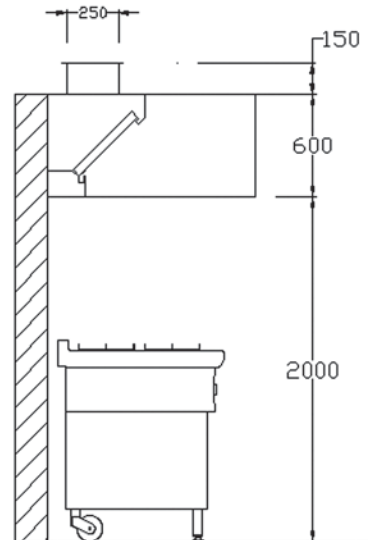
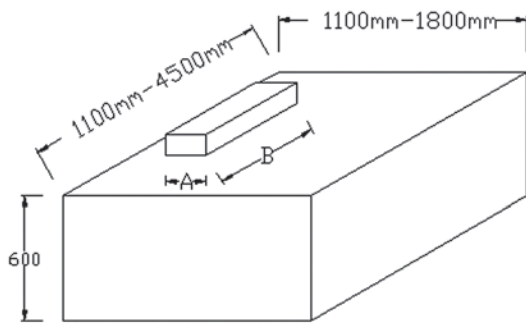

Specifications

LENGTH	FIRE DAMPER A X B	AIR VOLUME m ³ /s	LENGTH	FIRE DAMPER A X B	AIR VOLUME m ³ /s
1000-1200	250 X 400	0.55 - 0.66	2500-2700	250 X 900	1.37 - 1.48
1300-1500	250 X 500	0.71 - 0.82	2800-3000	250 X 1000	1.54 - 1.65
1600-1800	250 X 600	0.98 - 0.99	3100-3300	250 X 1100	1.70 - 1.81
1900-2100	250 X 700	1.04 - 1.15	3400-3600	250 X 1200	1.87 - 1.98
2200-2400	250 X 800	1.21 - 1.32	3700-3900	250 X 1300	2.03 - 2.10