

## FLATTOPS

850-e-Flattop

### Features

- 1. Top section** - Manufactured from 1.6mm 430 st/steel. Flattop is manufactured from 16mm mild steel.
- 2. Splash guards** - 2mm st/steel splash guards.
- 3. Body** - Front and sides are constructed from 0.9mm grade 430 st/steel.
- 4. Elements** - 3 x 3kw Incoloy elements with a low watts density per cm/squared. This prolongs element life.
- 5. Control** - Elements thermostatically controlled between 0-300 degrees celsius.



### Drawings

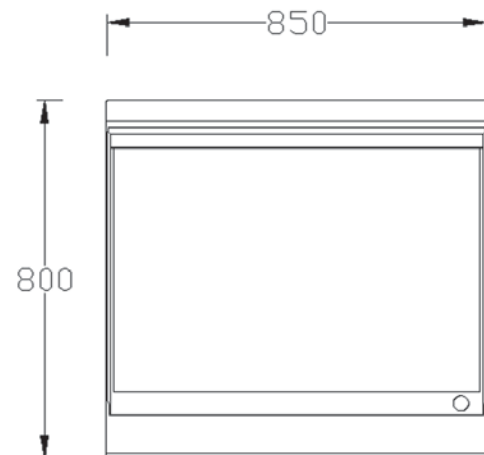
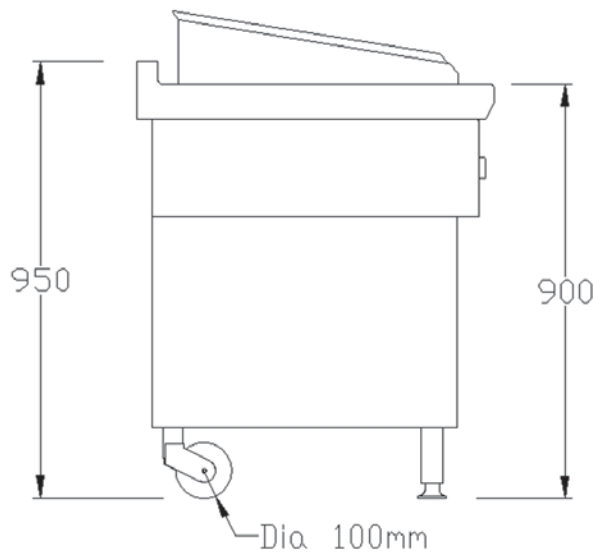

### Specifications

Dimensions: 850(W) x 800(D) x 950(H)  
 Electrical load: 9Kw, 380v, 3 phase, Neutral and Earth  
 Electrical connection: 2 meters (5 core) cable with fly leads

### Optional Extras

Body can be manufactured from: 304 st/steel  
 Front door to suite  
 Partially or fully ribbed