

FRYERS

575-dp-Fryer

Features

- 1. Pan** - Manufactured from 1.6mm grade 430 st/steel. Pan fitted with drain cock and unit comes supplied with oil receiver. Large cold zone area below elements.
- 2. Body** - Front, door and sides are constructed from 0.9mm grade 430 st/steel. Casters are fitted so as to be able to move equipment more easily.
- 3. Elements** - 6 x 4Kw Incoloy elements with a low watts density per cm/squared. This prolongs oil life and element life. Elements protected by a perforated st/steel screen.
- 4. Control** - Elements thermostatically controlled between 0-180 degrees celsius. Separate safety cut off thermostat is fitted, preset to 215 degrees celsius.

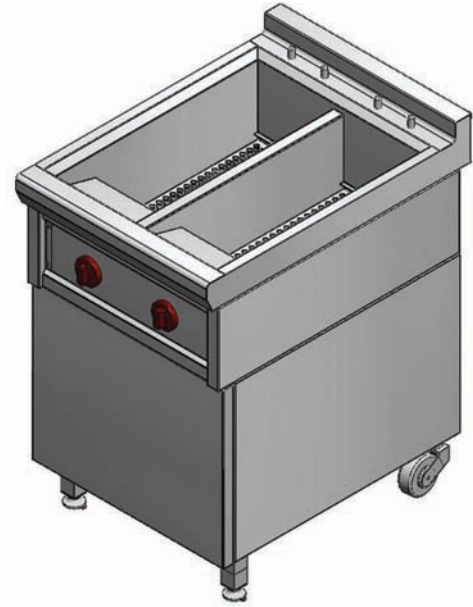

Drawings

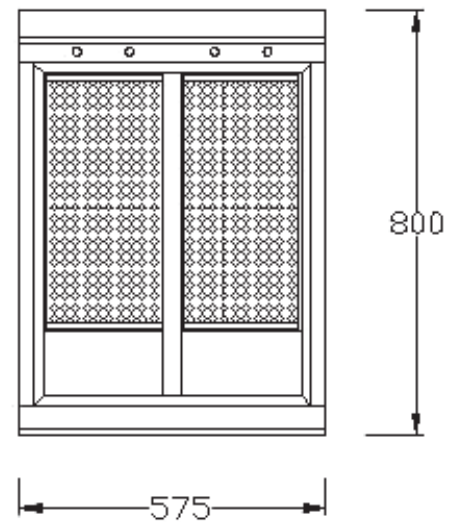
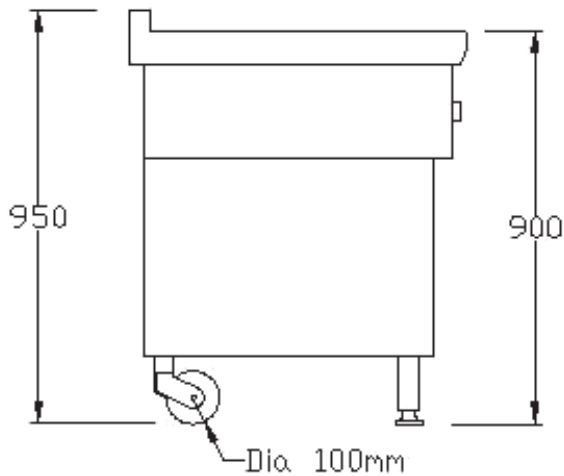

Specifications

Dimensions:	575(W) x 800(D) x 950(H)
Pan capacity:	2 x 15 Liters
Electrical load:	24Kw, 380v, 3 phase, Neutral and Earth
Electrical connection:	2 meters (5 core) cable with fly leads

Optional Extras

Body can be manufactured from:	304 st/steel
Filter paper	
Filter holder	
Programmable computer	
Frying baskets	